



## European Consortium presents circuits operating up to 650 GHz

***DOTFIVE is a 3-year project targeting a 0,5 THz SiGe Heterojunction Bipolar Transistor for the future development of communication, imaging or radar applications.***

San Francisco, February 11, 2009 – At the 2010 **ISSCC** (International Solid-State Circuits Conference) in San Francisco the EU-funded project labelled DOTFIVE and titled « Towards 0,5 TeraHertz Silicon/Germanium Heterojunction bipolar technology » presents first results of their silicon-based advanced bipolar transistors for future communication, imaging and automotive radar applications working at frequencies up to 650 GHz.

In the first paper a 160 GHz quadrature transmitter and receiver chipset from the University of Wuppertal in Germany is demonstrated. The 158-165 GHz chipset supports QAM modulation schemes and include VCO, prescaler, and amplifier chains. The receiver system NF is 11-14 dB and the transmitter output power is 5 dBm. The paper demonstrates silicon-based IC implementations at millimetre-wave frequencies that provide a broad set of solutions for communication, radar and imaging applications.

A second paper presents a striking example of what is achievable at THz frequencies. A 650 GHz imaging receiver with an on-chip folded-dipole antenna in a SiGe technology is presented. The sub-harmonic 162.5-GHz LO is supplied by an integrated 6-dBm LO driver amplifier. The receiver chip is 1.2 x 0.6 mm<sup>2</sup> large, provides a bandwidth of 635-665 GHz, and yields a -13-dBi conversion gain and a 42-dB NF. Both chips were implemented in a European SiGe BiCMOS technology with  $f_T=260\text{GHz}$  and  $f_{MAX}=380\text{GHz}$  fabricate at the IHP Microelectronics GmbH, Germany.

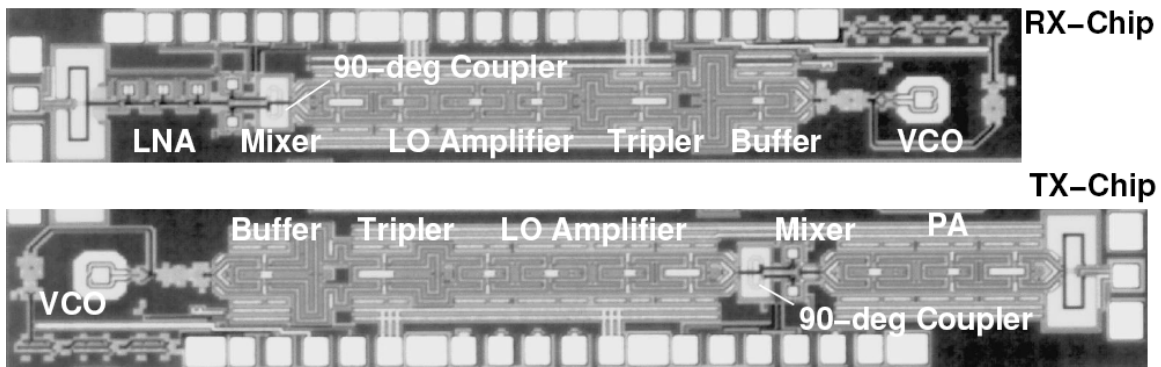

Figure 1: 160GHz transmitter and receiver chip-set micro-graphs.

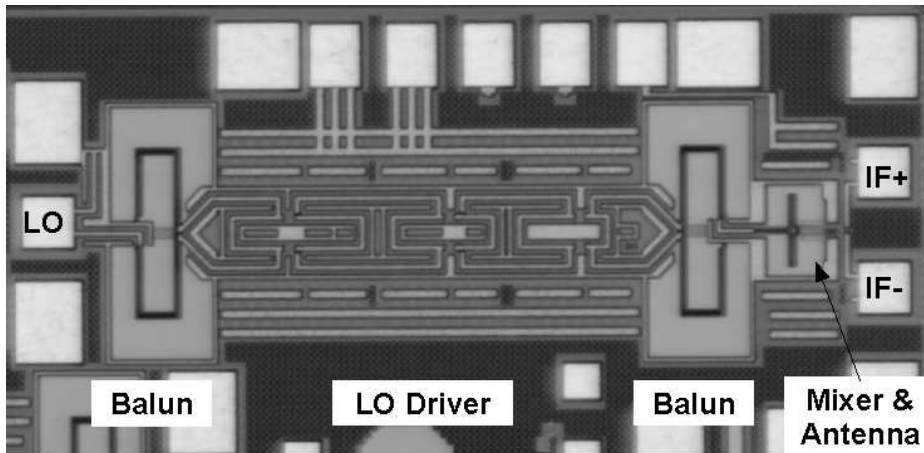

Figure 2: Die micrograph of the 1.2 x 0.6 mm<sup>2</sup> large 650GHz receiver front-end.

For more information on this new project, please visit [www.dotfive.eu](http://www.dotfive.eu):

#### Contacts

Project Coordinator:  
 Gilles THOMAS STMicroelectronics  
 Mail: gilles.thomas@st.com  
 TEL: +33 4 76 92 51 11